

**PROLINE**  
professional welding supplies

***Rotabroach***<sup>™</sup>

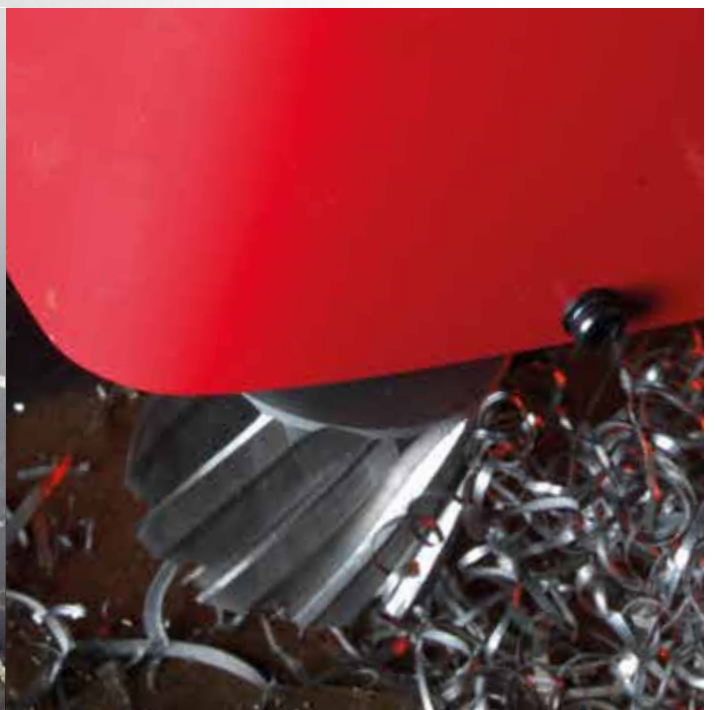

**CUTTING TOOLS  
& ACCESSORIES**



Ph: 0800 699 353  
[sales@prolinewelding.com](mailto:sales@prolinewelding.com)





# POWER To Cut Metal.™

We make cutting tools  
for metal to POWER the  
way you work.

#theoriginalname

Ph: 0800 699 353  
sales@prolinewelding.com

## CUTTERS & ACCESSORIES

ANNULAR CUTTER SELECTION .....	04
RAPTOR M2AL CUTTERS .....	05
RAPTOR TCT CUTTERS .....	06
RAPTOR CTCT CUTTERS .....	07
M2AL RAIL CUTTERS .....	09
TCT RAIL CUTTERS .....	10
TWIST DRILL WITH WELDON SHANK .....	11
TCT HOLESAWS .....	12
MINI CUTTERS .....	13
COUNTERSINKS .....	14
CUTTER ADAPTORS & TAPPING COLLETS .....	15
STEP DRILLS .....	16
CUTTER KITS & BUNDLES .....	16
ACCESSORIES .....	17-18
RAIL & TRAM ACCESSORIES .....	19

Ph: 0800 699 353  
sales@prolinewelding.com

# ANNULAR CUTTER SELECTION

## Core Cutter & Drilling Applications

R = Recommended G = Good P = Possible

Annular Core Cutter Category		M2AL	TCT	CTCT	Twist Drill	Mini Cutters	TCT Rail
Steel	<500N	R	R	R	R	R	G
	<750N	R	R	R	R	R	G
	<900N	R	R	R	R	R	G
	<1200N	P	R	R	P	P	G
	<1400N		R	R			G
	<1800N		P	R			P
Stainless Steel	<900N	P	R	R	P	P	P
Aluminium	<10%Si	G	R	G	G	G	P
	>10%Si	P	R	G	P	P	P
Copper	<100HB	G	G	G	G	G	P
Brass	<200HB	G	G	G	G	G	P
Cast Iron	<300HB	G	R	R	G	G	G
Sheet Metal						R	
Synthetics	Plastics	G	P	P	G	G	P
Rail Track					P		R
Tough Alloys	Hardox		P	R			P
	Inox		P	R			P
	Inconel		P	R			P

# RAPTOR M2AL CUTTERS



## Suitable for Drilling:

Steel Aluminium Copper / Brass Plastics

- Rotabroach™ Raptors are high performance annular cutters, with specially designed tooth geometry, only found on Raptor cutters.
- Made from M2AL, for greater cutter hardness, Raptor cutters deliver optimum performance, with increased speed of cut and maximum tool life.
- Can cut materials up to a maximum tensile strength of 900 N/mm<sup>2</sup>



Stage hardened allowing for greater flexibility during operation.



Designed to give longer tool life and faster cutting times.



When using annular cutters we always recommend you use a pilot pin.

SRA3057	RAP110 - RAP120
SRA25	RAP130 - RAP600
RA3013	RAPL120
SRA50	RAPL130 - RAPL650

## RAPTOR M2AL CUTTERS • Specifications

Dia mm	25mm D.O.C	50mm D.O.C	Dia mm	25mm D.O.C	50mm D.O.C	Dia mm	25mm D.O.C	50mm D.O.C	Dia mm	25mm D.O.C	50mm D.O.C	Dia mm	25mm D.O.C	50mm D.O.C
11	RAP110		22	RAP220	RAPL220	33	RAP330	RAPL330	44	RAP440	RAPL440	55	RAP550	RAPL550
12	RAP120	RAPL120	23	RAP230	RAPL230	34	RAP340	RAPL340	45	RAP450	RAPL450	56	RAP560	RAPL560
13	RAP130	RAPL130	24	RAP240	RAPL240	35	RAP350	RAPL350	46	RAP460	RAPL460	57	RAP570	RAPL570
14	RAP140	RAPL140	25	RAP250	RAPL250	36	RAP360	RAPL360	47	RAP470	RAPL470	58	RAP580	RAPL580
15	RAP150	RAPL150	26	RAP260	RAPL260	37	RAP370	RAPL370	48	RAP480	RAPL480	59	RAP590	RAPL590
16	RAP160	RAPL160	27	RAP270	RAPL270	38	RAP380	RAPL380	49	RAP490	RAPL490	60	RAP600	RAPL600
17	RAP170	RAPL170	28	RAP280	RAPL280	39	RAP390	RAPL390	50	RAP500	RAPL500	61		RAPL610
18	RAP180	RAPL180	29	RAP290	RAPL290	40	RAP400	RAPL400	51	RAP510	RAPL510	62		RAPL620
19	RAP190	RAPL190	30	RAP300	RAPL300	41	RAP410	RAPL410	52	RAP520	RAPL520	63		RAPL630
20	RAP200	RAPL200	31	RAP310	RAPL310	42	RAP420	RAPL420	53	RAP530	RAPL530	64		RAPL640
21	RAP210	RAPL210	32	RAP320	RAPL320	43	RAP430	RAPL430	54	RAP540	RAPL540	65		RAPL650



# RAPTOR TCT CUTTERS



- Raptor TCT cutters are harder and able to resist higher temperatures resulting in less wear, providing a longer tool life when comparing against competitor products.
- Super micro-grain carbide tips for the toughest of materials.
- The special Rotabroach™ 3 tooth geometry provides even tooth loading for a smooth and vibration free cut.

## RAPTOR TCT CUTTERS • Specifications

Dia mm	35mm D.O.C	50mm D.O.C	75mm D.O.C	100mm D.O.C	Dia mm	35mm D.O.C	50mm D.O.C	75mm D.O.C	100mm D.O.C	Dia mm	35mm D.O.C	50mm D.O.C	75mm D.O.C	100mm D.O.C
12	CWC12	CWCL12	CWCT12	CWCX12	42	CWC42	CWCL42	CWCT42	CWCX42	72	CWCL72	CWCT72	CWCX72	
13	CWC13	CWCL13	CWCT13	CWCX13	43	CWC43	CWCL43	CWCT43	CWCX43	73	CWCL73	CWCT73	CWCX73	
14	CWC14	CWCL14	CWCT14	CWCX14	44	CWC44	CWCL44	CWCT44	CWCX44	74	CWCL74	CWCT74	CWCX74	
15	CWC15	CWCL15	CWCT15	CWCX15	45	CWC45	CWCL45	CWCT45	CWCX45	75	CWCL75	CWCT75	CWCX75	
16	CWC16	CWCL16	CWCT16	CWCX16	46	CWC46	CWCL46	CWCT46	CWCX46	76	CWCL76	CWCT76	CWCX76	
17	CWC17	CWCL17	CWCT17	CWCX17	47	CWC47	CWCL47	CWCT47	CWCX47	77	CWCL77	CWCT77	CWCX77	
18	CWC18	CWCL18	CWCT18	CWCX18	48	CWC48	CWCL48	CWCT48	CWCX48	78	CWCL78	CWCT78	CWCX78	
19	CWC19	CWCL19	CWCT19	CWCX19	49	CWC49	CWCL49	CWCT49	CWCX49	79	CWCL79	CWCT79	CWCX79	
20	CWC20	CWCL20	CWCT20	CWCX20	50	CWC50	CWCL50	CWCT50	CWCX50	80	CWCL80	CWCT80	CWCX80	
21	CWC21	CWCL21	CWCT21	CWCX21	51	CWC51	CWCL51	CWCT51	CWCX51	81	CWCL81	CWCT81	CWCX81	
22	CWC22	CWCL22	CWCT22	CWCX22	52	CWC52	CWCL52	CWCT52	CWCX52	82	CWCL82	CWCT82	CWCX82	
23	CWC23	CWCL23	CWCT23	CWCX23	53		CWCL53	CWCT53	CWCX53	83	CWCL83	CWCT83	CWCX83	
24	CWC24	CWCL24	CWCT24	CWCX24	54		CWCL54	CWCT54	CWCX54	84	CWCL84	CWCT84	CWCX84	
25	CWC25	CWCL25	CWCT25	CWCX25	55		CWCL55	CWCT55	CWCX55	85	CWCL85	CWCT85	CWCX85	
26	CWC26	CWCL26	CWCT26	CWCX26	56		CWCL56	CWCT56	CWCX56	86	CWCL86	86CWCT	CWCX86	
27	CWC27	CWCL27	CWCT27	CWCX27	57		CWCL57	CWCT57	CWCX57	87	CWCL87	CWCT87	CWCX87	
28	CWC28	CWCL28	CWCT28	CWCX28	58		CWCL58	CWCT58	CWCX58	88	CWCL88	CWCT88	CWCX88	
29	CWC29	CWCL29	CWCT29	CWCX29	59		CWCL59	CWCT59	CWCX59	89	CWCL89	CWCT89	CWCX89	
30	CWC30	CWCL30	CWCT30	CWCX30	60		CWCL60	CWCT60	CWCX60	90	CWCL90	CWCT90	CWCX90	
31	CWC31	CWCL31	CWCT31	CWCX31	61		CWCL61	CWCT61	CWCX61	91	CWCL91	CWCT91	CWCX91	
32	CWC32	CWCL32	CWCT32	CWCX32	62		CWCL62	CWCT62	CWCX62	92	CWCL92	CWCT92	CWCX92	
33	CWC33	CWCL33	CWCT33	CWCX33	63		CWCL63	CWCT63	CWCX63	93	CWCL93	CWCT93	CWCX93	
34	CWC34	CWCL34	CWCT34	CWCX34	64		CWCL64	CWCT64	CWCX64	94	CWCL94	CWCT94	CWCX94	
35	CWC35	CWCL35	CWCT35	CWCX35	65		CWCL65	CWCT65	CWCX65	95	CWCL95	CWCT95	CWCX95	
36	CWC36	CWCL36	CWCT36	CWCX36	66		CWCL66	CWCT66	CWCX66	96	CWCL96	CWCT96	CWCX96	
37	CWC37	CWCL37	CWCT37	CWCX37	67		CWCL67	CWCT67	CWCX67	97	CWCL97	CWCT97	CWCX97	
38	CWC38	CWCL38	CWCT38	CWCX38	68		CWCL68	CWCT68	CWCX68	98	CWCL98	CWCT98	CWCX98	
39	CWC39	CWCL39	CWCT39	CWCX39	69		CWCL69	CWCT69	CWCX69	99	CWCL99	CWCT99	CWCX99	
40	CWC40	CWCL40	CWCT40	CWCX40	70		CWCL70	CWCT70	CWCX70	100	CWCL100	CWCT100	CWCX100	
41	CWC41	CWCL41	CWCT41	CWCX41	71		CWCL71	CWCT71	CWCX71					



Unique flute design for fast material flow.



When using annular cutters we always recommend you use a pilot pin.

SRA90	CWC12-CWC17	RA3120	CWCT18-CWCT65
RA3089	CWC18-CWC52	RA3121	CWCT66+
SRA50	CWCL12-CWCL17	20ZAXL400P	CWCX12-CWCX17
RA356	CWCL18-CWCL65	RA3122	CWCX18-CWCX65
RA3094	CWCL66+	RA3123	CWCX66+
SRA130	CWCT12-CWCT17		

# RAPTOR CTCT CUTTERS

Officially approved by SSAB and tested to drill Hardox wear plate up to a hardness level of 500 Brinell.

SSAB



- Cermet carbide tips give maximum cutting strength and stability, while maximising tool life. Cut 15x more holes than HSS and 6x more than TCT.
- Cuts the toughest of materials. Drill Hardox plate, Inox, Inconel, Cast Iron, Fine Grain Steel and other tough alloys.
- 3 step alternate tooth geometry to reduce heat generation during cutting and custom designed flutes for better material removal.

## RAPTOR CTCT CUTTERS • Specifications

Dia mm	25mm D.O.C	Dia mm	25mm D.O.C	Dia mm	25mm D.O.C
18	CTCT18	26	CTCT26	34	CTCT34
19	CTCT19	27	CTCT27	35	CTCT35
20	CTCT20	28	CTCT28	36	CTCT36
21	CTCT21	29	CTCT29	37	CTCT37
22	CTCT22	30	CTCT30	38	CTCT38
23	CTCT23	31	CTCT31	39	CTCT39
24	CTCT24	32	CTCT32	40	CTCT40
25	CTCT25	33	CTCT33		



Rotabroach™ Raptor CTCT cutters have a specially designed straight flute designed for better material removal.



Cermet carbide tips for maximum cutting capability in the hardest of material.



When using annular cutters we always recommend you use a pilot pin.

SRA25 CTCT18 - CTCT40



- Size range: 18-40mm
- Cutting depth: 25mm
- Cuts through metals up to a strength of 1800N/mm<sup>2</sup>
- Pilot pins: 18-40mm (SRA25)



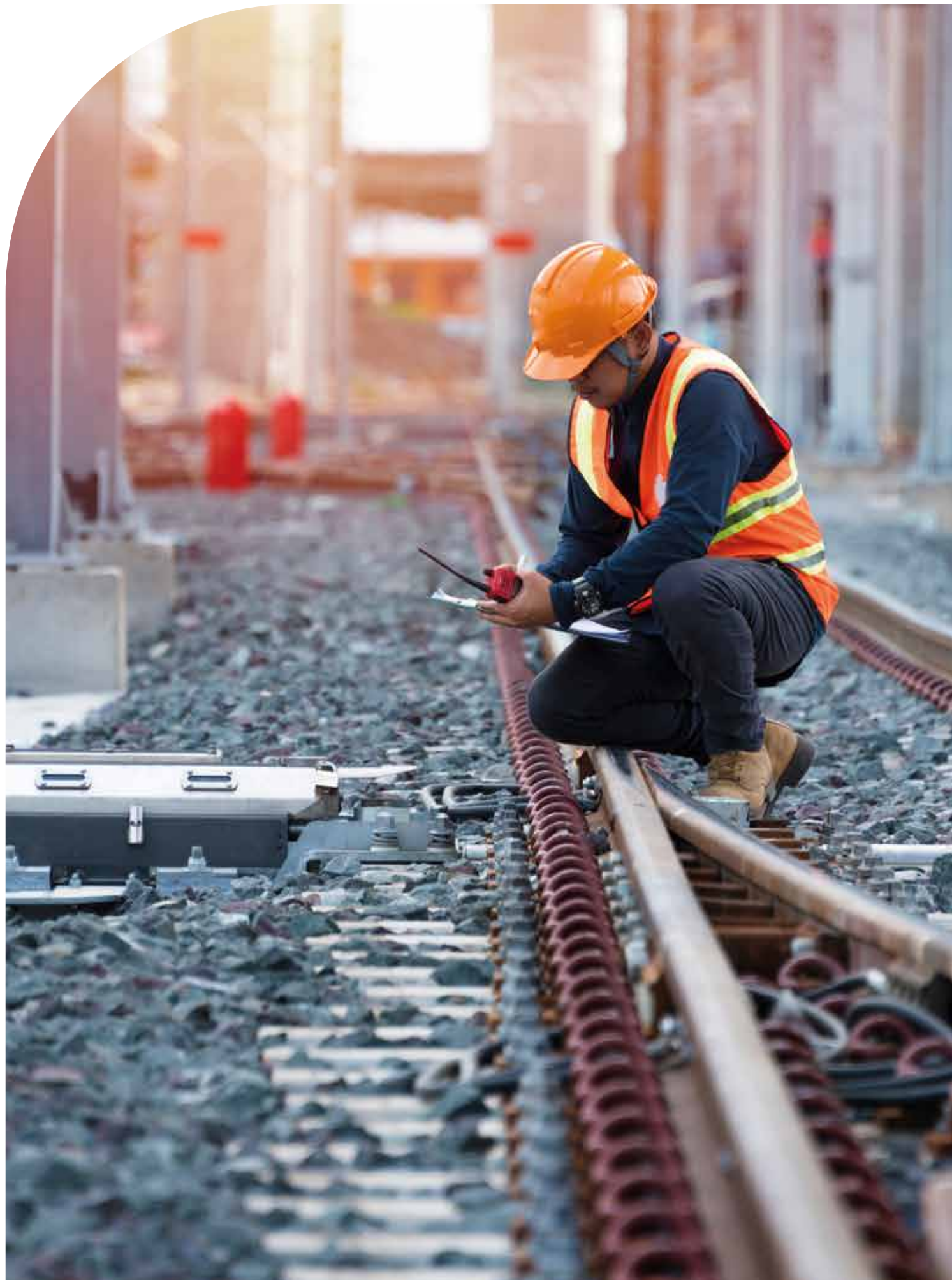

## M2AL RAIL CUTTERS



Tooth geometry specifically designed for cutting rail track.



Stage hardened allowing for greater flexibility during operation.

### Suitable for Drilling:



- Specific tooth geometry, designed for rail applications.
- Ideal for drilling holes at slower speeds.
- Designed for rail track.
- High performance cutters, manufactured from M2AL steel and heat-treated to maximize cutter hardness.



When using annular cutters we always recommend you use a pilot pin.

SRA25	SRCV130 - SRCV360
SRA50	SRCV130 - SRCV360

### M2AL RAIL CUTTERS • Specifications

Dia mm	25mm D.O.C	50mm D.O.C	Dia mm	25mm D.O.C	50mm D.O.C
13	SRCV130	SRCV130	25	SRCV250	SRCV250
14	SRCV140	SRCV140	26	SRCV260	SRCV260
15	SRCV150	SRCV150	27	SRCV270	SRCV270
16	SRCV160	SRCV160	28	SRCV280	SRCV280
17	SRCV170	SRCV170	29	SRCV290	SRCV290
18	SRCV180	SRCV180	30	SRCV300	SRCV300
19	SRCV190	SRCV190	31	SRCV310	SRCV310
20	SRCV200	SRCV200	32	SRCV320	SRCV320
21	SRCV210	SRCV210	33	SRCV330	SRCV330
22	SRCV220	SRCV220	34	SRCV340	SRCV340
23	SRCV230	SRCV230	35	SRCV350	SRCV350
24	SRCV240	SRCV240	36	SRCV360	SRCV360





# TCT RAIL CUTTERS



## Suitable for Drilling:



- Carbide tipped for extended tool life and specific tooth geometry, manufactured for cutting rail track.
- Rail TCT cutters are specified to resist higher temperatures and drill the world's toughest rail.
- Designed for maximum stability and strength, with a straight flute design for better material removal and tip strength.

## TCT RAIL CUTTERS • Specifications

Dia mm	25mm D.O.C	50mm D.O.C	Dia mm	25mm D.O.C	50mm D.O.C
18	SCRWC18	SCRWCL18	30	SCRWC30	SCRWCL30
19	SCRWC19	SCRWCL19	31	SCRWC31	SCRWCL31
20	SCRWC20	SCRWCL20	32	SCRWC32	SCRWCL32
21	SCRWC21	SCRWCL21	33	SCRWC33	SCRWCL33
22	SCRWC22	SCRWCL22	34	SCRWC34	SCRWCL34
23	SCRWC23	SCRWCL23	35	SCRWC35	SCRWCL35
24	SCRWC24	SCRWCL24	36	SCRWC36	SCRWCL36
25	SCRWC25	SCRWCL25			
26	SCRWC26	SCRWCL26			
27	SCRWC27	SCRWCL27			
28	SCRWC28	SCRWCL28			
29	SCRWC29	SCRWCL29			



Rotabroach™ TCT Rail cutters have a specially designed straight flute to give a greater stability whilst drilling.



Specially designed carbide tips for maximum cutting capability in the hardest of material.



When using annular cutters we always recommend you use a pilot pin.

SRA25	SCRWC18 - SCRWC36
SRA50	SCRWCL18 - SCRWCL36*

\*Available upon request

# TWIST DRILL WITH WELDON SHANK



- Use with any weldon shank arbor to drill small diameter holes where using an annular cutter is not suitable.
- Central coolant hole ensures the lubricant can travel to the tip of the drill giving a longer tool life compared to standard twist drills.
- Manufactured from M42 material enabling the tool to cut hard materials.

## TWIST DRILL WITH WELDON SHANK • Specifications

Size Range	6mm - 13.5mmø / RRTW060 - RRTW135
Cutting Depths	25mm
Max Tensile Strength	<1100N/mm2
Ideal For	Rail Track, Structural Steel & Stainless Steel

## ROTABROACH™ • Twist Drill Adaptors

Rotabroach's™ Twist Drill Adaptors are designed for use with stub length drills from 4mm - 13.5mm. Machined to a high tolerance and finish ensuring concentricity is maintained.

Part No.	Size	Part No.	Size
RD2003/040	4mm	RD2003/098	9.8mm
RD2003/060	6mm	RD2003/100	10mm
RD2003/070	7mm	RD2003/110	11mm
RD2003/072	7.2mm	RD2003/120	12mm
RD2003/080	8mm	RD2003/130	13mm
RD2003/085	8.5mm	RD2003/135	13.5mm
RD2003/090	9mm		

Can be adapted for any twist drill up to 13.5mm



Fits any weldon shank arbor

Perfect for drilling bonding holes in rail applications. The ideal solution for drilling small diameter holes with a magnetic drill.



Heavy duty geometry for easy cutting and increased life. Spiral flute for faster material removal.



Weldon shank with low tolerances for increased stability.

# TCT HOLESAWS



## Suitable for Drilling:

Structural Steel  Stainless Steel  Pipes  Sheet Metal

- Manufactured with high quality solid carbide tips for maximum performance and reliability.
- High quality M35 drill, spring loaded for fast waste material ejection.
- Vastly increased tool life compared to bi-metal holesaws.
- Used in conjunction with drill chuck.

## HOLESAWS • Specifications

Size Range	14mm - 100mm $\varnothing$ / RHS1625 - RHS10025
Cutting Depths	15mm in Pistol Drill / 25mm in Magnetic Drill
Max Tensile Strength	<1400N/mm <sup>2</sup>
Ideal For	Structural Steel, Stainless Steel & Pipework

## TCT HOLESAWS • Specifications

Dia mm	25mm D.O.C	50mm D.O.C	Dia mm	25mm D.O.C	50mm D.O.C	Dia mm	25mm D.O.C	50mm D.O.C	Dia mm	25mm D.O.C	50mm D.O.C	Dia mm	25mm D.O.C	50mm D.O.C
14	RHS1425		33	RHS3325	RHS3350	52	RHS5225	RHS5250	71	RHS7125		90	RHS9025	RHS9050
15	RHS1525		34	RHS3425	RHS3450	53	RHS5325	RHS5350	72	RHS7225	RHS7250	91	RHS9125	
16	RHS1625		35	RHS3525	RHS3550	54	RHS5425	RHS5450	73	RHS7325	RHS7350	92	RHS9225	
17	RHS1725		36	RHS3625	RHS3650	55	RHS5525	RHS5550	74	RHS7425		93	RHS9325	
18	RHS1825		37	RHS3725	RHS3750	56	RHS5625	RHS5650	75	RHS7525		94	RHS9425	
19	RHS1925	RHS1950	38	RHS3825	RHS3850	57	RHS5725	RHS5750	76	RHS7625		95	RHS9525	RHS9550
20	RHS2025	RHS2050	39	RHS3925	RHS3950	58	RHS5825	RHS5850	77	RHS7725		96	RHS9625	
21	RHS2125	RHS2150	40	RHS4025	RHS4050	59	RHS5925	RHS5950	78	RHS7825		97	RHS9725	
22	RHS2225	RHS2250	41	RHS4125	RHS4150	60	RHS6025	RHS6050	79	RHS7925		98	RHS9825	
23	RHS2325	RHS2350	42	RHS4225	RHS4250	61	RHS6125	RHS6150	80	RHS8025		99	RHS9925	
24	RHS2425	RHS2450	43	RHS4325	RHS4350	62	RHS6225	RHS6250	81	RHS8125		100	RHS10025	RHS10050
25	RHS2525	RHS2550	44	RHS4425	RHS4450	63	RHS6325	RHS6350	82	RHS8225		101	RHS10125	
26	RHS2625	RHS2650	45	RHS4525	RHS4550	64	RHS6425	RHS6450	83	RHS8325		102	RHS10225	
27	RHS2725	RHS2750	46	RHS4625	RHS4650	65	RHS6525	RHS6550	84	RHS8425		103	RHS10325	
28	RHS2825	RHS2850	47	RHS4725	RHS4750	66	RHS6625		85	RHS8525		104	RHS10425	
29	RHS2925	RHS2950	48	RHS4825	RHS4850	67	RHS6725		86	RHS8625		105	RHS10525	
30	RHS3025	RHS3050	49	RHS4925	RHS4950	68	RHS6825		87	RHS8725		106	RHS10625	
31	RHS3125	RHS3150	50	RHS5025	RHS5050	69	RHS6925		88	RHS8925				
32	RHS3225	RHS3250	51	RHS5125	RHS5150	70	RHS7025		89	RHS8925				

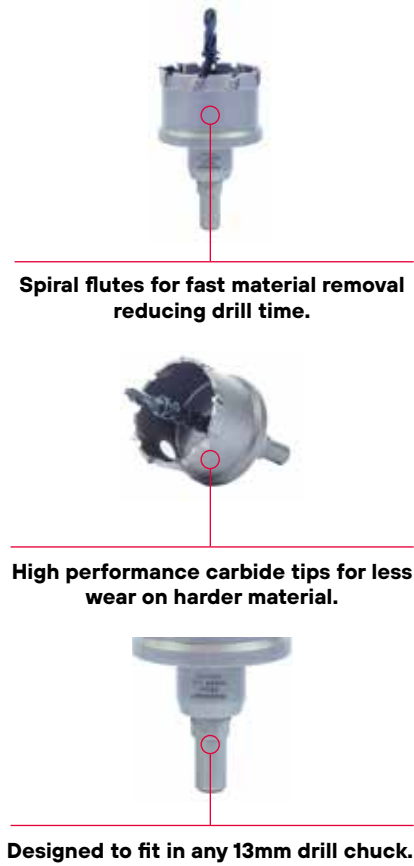

Spiral flutes for fast material removal reducing drill time.

High performance carbide tips for less wear on harder material.

Designed to fit in any 13mm drill chuck.

Kit Part Number	Description
RHSKIT1	Set contains standard short cutters with the following sizes 14mm/16mm/18mm/20mm/22mm with 25mm depth of cut

# MINI CUTTERS



## Suitable for Drilling:

Plastic  Sheet Metal  Pipes

- Precision ground teeth and flutes ensure fast, accurate and burr-free holes in seconds.
- For use on sheet metal, pipes and plastics.
- Cut 3 times faster and last 10 times longer than twist drills.
- Low power consumption giving a longer life to cordless drills.

## MINI CUTTERS • Specifications

Size Range	6mm - 25mm $\varnothing$ / RCM060 - RCM250
Cutting Depths	*6.4mm up to $\varnothing$ 20mm / 12.7mm over $\varnothing$ 20mm
Max Tensile Strength	<900N/mm <sup>2</sup>
Ideal For	Sheet Metal, Pipes & Plastics

\* for 21-25mm depth, RA118 arbor required

Dia mm	Part No.	D.O.C mm	Arbor Required	Dia mm	Part No.	D.O.C mm	Arbor Required
6	RCM060	6.4	RA116/ RA117	16	RCM160	6.4	RA116/ RA117
7	RCM070	6.4	RA116/ RA117	17	RCM170	6.4	RA116/ RA117
8	RCM080	6.4	RA116/ RA117	18	RCM180	6.4	RA116/ RA117
9	RCM090	6.4	RA116/ RA117	19	RCM190	6.4	RA116/ RA117
10	RCM100	6.4	RA116/ RA117	20	RCM200	6.4	RA116/ RA117
11	RCM110	6.4	RA116/ RA117	21	RCM210	12.7	RA118
12	RCM120	6.4	RA116/ RA117	22	RCM220	12.7	RA118
13	RCM130	6.4	RA116/ RA117	23	RCM230	12.7	RA118
14	RCM140	6.4	RA116/ RA117	24	RCM240	12.7	RA118
15	RCM150	6.4	RA116/ RA117	25	RCM250	12.7	RA118

- Available in sizes 6mm - 25mm.
- Available as single items or kits. Kit includes:  
8mm - 20mm  
RCM080, RCM100  
RCM120, RCM140  
RCM160, RCM180  
RCM200  
RK603 - 1/2" Arbor - RA116  
RK604 - 3/8" Arbor - RA117



Unique tooth design for less wear.

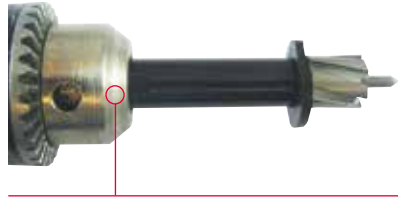

Designed to fit in any 1/2" or 3/8" drill chuck in hand held drill or drill press.

- See page 17 for our extension arbors and Morse taper arbors.



# COUNTERSINKS



## COUNTERSINKS

- Manufactured from extremely tough high speed steel.
- Suitable for all types of portable drills with 3/4" shank.
- 3 cutting edges, smooth chamfering and high surface finish.

Part No.	Range
CK30	Countersinks up to ø30mm
CK40	Countersinks up to ø40mm
CK55	Countersinks up to ø55mm

## PILOTED TCT COUNTERSINKS

- Manufactured from extremely tough high speed steel.
- TCT cutting edge for greater tool life and harder materials.
- Suitable for all types of portable drills with 3/4" shank.
- 3 cutting edges, smooth chamfering and high surface finish.
- Manufactured with pilot bore for greater stability and accuracy.
- Pilots can be supplied separately.

Part No.	Range
RPCC201	Countersinks up to ø42mm
RPCC100	Countersinks kit includes pilots for 14mm, 18mm & 22mm

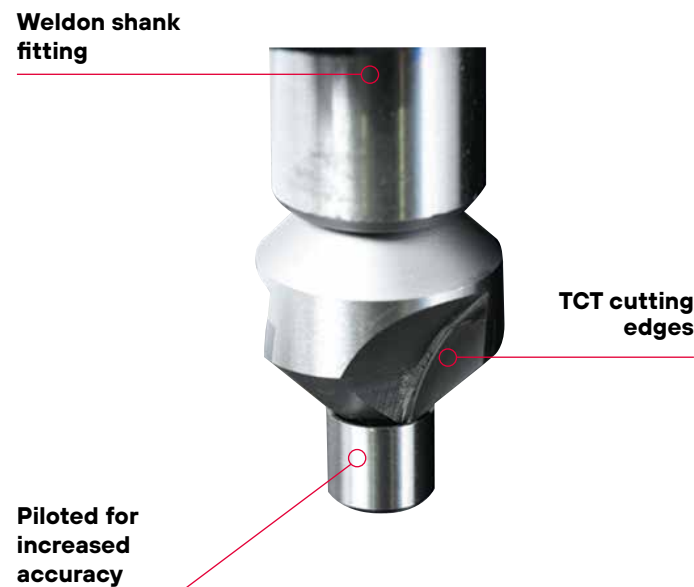
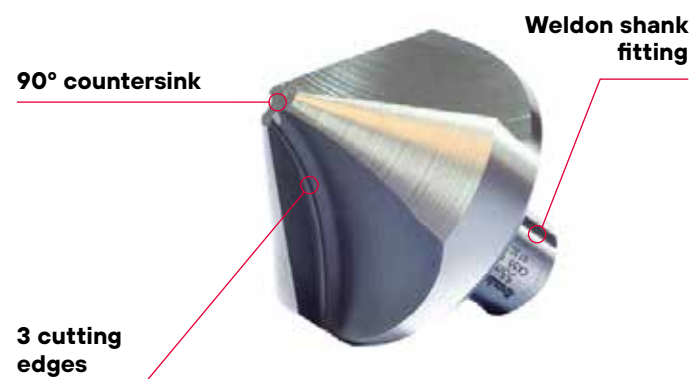

# CUTTER ADAPTORS & TAPPING COLLETS



## CUTTER ADAPTORS

Adapt Rotabroach™ cutters to use in competitor machines, with a 'quick fit' system.

Conversion	Range
CQA01	Fein Quick-In Shank
CQA02	One-Touch Shank
CQA03	Nitto Threaded Adaptor

## TAPPING COLLETS

### Morse Taper - Collet Holders

MT8415403	SIZE 1 - 3MT COLLET HOLDER
MT8425403	SIZE 2 - 3MT COLLET HOLDER
MT8435403	SIZE 3 - 3MT COLLET HOLDER

### Size 1 - Standard Collets

MT861008	M6 STANDARD TAP COLLET
----------	------------------------

### Size 2 - Standard Collets

MT8620009	M7 STANDARD TAP COLLET
MT8620010	M8/M11 STANDARD TAP COLLET
MT8620011	M9/M12 STANDARD TAP COLLET
MT8620012	M10 STANDARD TAP COLLET
MT8620013	M14 STANDARD TAP COLLET
MT8620014	M16 STANDARD TAP COLLET
MT8620015	M18/M20 STANDARD TAP COLLET
MT8620016	M22 STANDARD TAP COLLET
MT8620017	M24 STANDARD TAP COLLET

### Size 2 - Clutched Collets

MT8622010	M8 CLUTCHED COLLET
MT8622011	M9 CLUTCHED COLLET
MT8622012	M10 CLUTCHED COLLET
MT8622013	M14 CLUTCHED COLLET
MT8622014	M16 CLUTCHED COLLET
MT8622015	M18 CLUTCHED COLLET
MT8622016	M22 CLUTCHED COLLET
MT8622017	M24 CLUTCHED COLLET
MT8622050	M11 CLUTCHED COLLET
MT8622051	M12 CLUTCHED COLLET
MT8622052	M20 CLUTCHED COLLET

### Size 3 - Standard Collets

MT8630013	M14 STANDARD TAP COLLET
MT8630014	M16 STANDARD TAP COLLET
MT8630015	M18/M20 STANDARD TAP COLLET
MT8630016	M22 STANDARD TAP COLLET
MT8630017	M24 STANDARD TAP COLLET
MT8630018	M27/M30 STANDARD TAP COLLET

### Size 3 - Clutched Collet

MT8632053	8632053 - M30 CLUTCHED COLLET
-----------	-------------------------------



## STEP DRILLS

The **STEP DRILL** allows a number of popular hole sizes to be drilled with just one tool.

### STEP DRILLS - FIVE STEPS • Specifications

12mm plate - with 3/4" Weldon Shank

Part no.	Item no	Description
19X8M5	19000	Starter - 8, 10, 12, 14, 16mm
19X10M5	19002	Starter - 10, 12, 14, 16, 18mm
19X20M5	19004	Starter - 20, 22, 24, 26, 28mm
19X30M5	19006	Follow on - 30, 32, 34, 36, 38mm
19X40M5	19008	Follow on - 40, 42, 44, 46, 48mm

### STEP DRILLS - THREE STEPS • Specifications

25mm plate - with 3/4" Weldon Shank

Part no.	Item no	Description
19X10M3	19020	Starter - 10, 12, 14mm
19X16M3	19022	Starter - 16, 18, 20mm
19X22M3	19024	Follow on - 22, 24, 26mm
19X28M3	19026	Follow on - 28, 30, 32mm
19X34M3	19028	Follow on - 34, 36, 38mm
19X40M3	19030	Follow on - 40, 42, 44mm
19X46M3	19032	Follow on - 46, 48, 50mm



## CUTTER KITS & BUNDLES



Our range of cutters and power tool accessories are available in **KITS AND BUNDLES**. Available in popular sizes and different grades of materials, these kits are designed to give you the **POWER** to get the job done.

Find them online: [www.rotabroach.co.uk/products/kits-bundles](http://www.rotabroach.co.uk/products/kits-bundles)

## ACCESSORIES

Fits any weldon shank machine



Range of extensions available

### EXTENSION ARBOR

Designed for extended reach, whilst maintaining concentricity over various lengths.

Part No.	Extension
RD2091	25mm
RD2090	50mm
RD2092	75mm
RD2102	100mm
RD2103	150mm
RD2104	200mm
RD2105	250mm

Range of morse taper shanks available



High quality manufacturing

### MORSE TAPER ARBORS

Rotabroach™ produce a number of 'Morse Tapers' from 2 morse - 5 morse, to allow the use of our cutters in any morse taper machine. All come with coolant feed.

Part No.	Morse Taper	Shank Dia	Depth
CA120	2	19.05mm	50mm
CA130	3	19.05mm	50mm
CA130 + Pilot RA3120	3	19.05mm	75mm
CA130 + Pilot RA3122	3	19.05mm	100mm
CA130X	3	32mm	50mm
CA130X + Pilot RA3121	3	32mm	75mm
CA130X + Pilot RA3123	3	32mm	100mm
CA1375 + Pilot SRA130	3	19.05mm	75mm
CA3310 + Pilot 20ZAXL400P	3	32mm	100mm
CA140	4	19.05mm	50mm
CA1475	4	19.05mm	75mm
CA340	4	32mm	50mm
CA3475	4	32mm	75mm
CA1575	5	19.05mm	75mm
CA3510	5	32mm	100mm
CA1510	5	19.05mm	100mm

## ACCESSORIES

## RAIL & TRAM ACCESSORIES

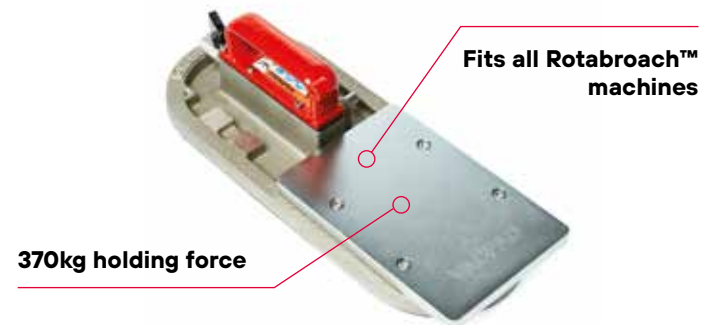

### VACUUM PAD

For applications where it is unsuitable to fit the magnet of a drill directly to the material surface.

With a holding force of 368kg at the centre position, magnetic drills can be used on even non-magnetic surfaces.

An air supply of 4 cubic feet per minute and minimum pressure of 70psi is required.

Part No.	DB121
----------	-------

### CUTTING LUBRICANTS

Rotabroach™ cutting fluid and lubricants have been formulated to ensure you get the most out of your cutters.

For applications where fluid is unsuitable we have our 'Slick-Stik™' lubrication sticks ensuring you can still use lubrication even when working at height.



Part No.	Volume
RD208	1L Neat Cutting Fluid
RD229	5L Neat Cutting Fluid
RD2094	Cutting Paste 500g
RD40068	Slick-Stik™ 1.68oz
RD40065	Slick-Stik™ 16oz

### SWARF STICK

This hand held lightweight tool helps attract ferrous metal chippings and swarf which can easily be removed from the work area.

Simply push in the handle and place the tool over the metal chippings and swarf. The stick will attract the waste to itself.

Part No.	CT/010/100
----------	------------

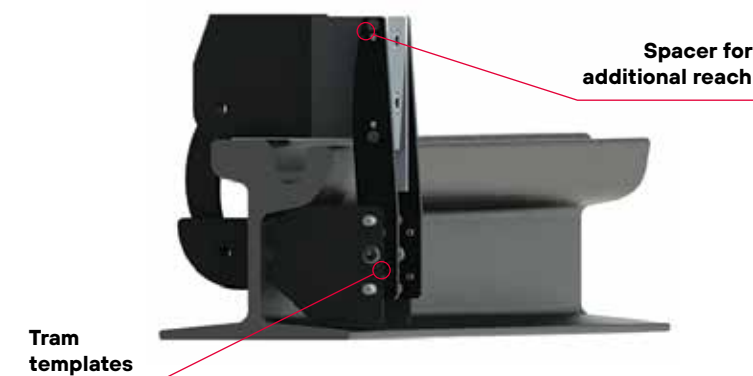
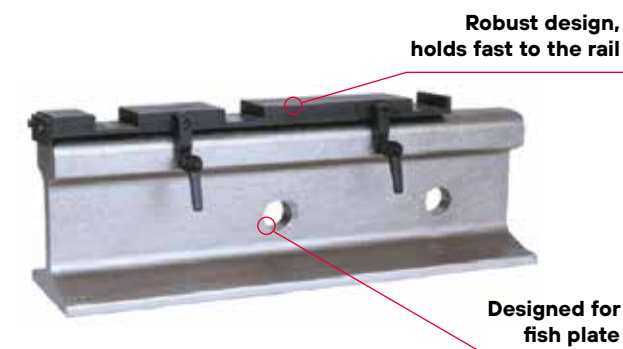

### BESPOKE SOLUTIONS

Our rail drills are adapted to suit whatever rail form you need.

We have most of the common rail forms on file, plus our design team can accommodate any specific requests.

### HOLE CENTRE LOCATOR

- Used for the correct measurements for fish plates, S&T, bonding holes and axle counters.
- All rail forms and spacings can be catered for and our designers will be able to deal with any special requests.

### MULTIFORM TEMPLATES

- Multiform templates are a fast, easy and accurate system, to ensure drilling at the correct height.
- Two rail profiles are allowed per template, giving you flexibility to use on a multitude of rail.

### TRAM ADAPTOR

- The Rhino 4 and Rhino E are both adaptable for drilling tram rail. The tram adaptor kit elongates the rail clamp to fit over wider rails.
- With a number of different templates, we can support most common types of tram rail requirements.
- Our design team are also able to design to your specific requirements.



**PROLINE**  
professional welding supplies

*Rotabroach*

---

**POWER To  
Cut Metal.** <sup>TM</sup>

---

Ph: 0800 699 353  
[sales@prolinewelding.com](mailto:sales@prolinewelding.com)